

外挂式机柜空调操作及使用说明书

DTS 8000E 系列

Operating and assembly instruction

For side-mounted cooling units

DTS 8000E



1 手册提示.....	7
2 搬运.....	7
2.1 运输.....	7
2.2 储运.....	7
2.3 开箱.....	7
3 供货范围.....	8
4 一般信息.....	8
5 铭牌.....	8
6 安全.....	9
7 功能.....	9
7.1 配置与功能.....	9
7.2 工作原理.....	9
7.3 冷凝物.....	10
8 技术规格书.....	10
8.1 电气原理图.....	10
8.2 备品备件.....	11
8.3 安装开孔.....	12
8.4 气流原理.....	15
8.5 技术参数.....	15
9 安装.....	22
9.1 概述.....	22
9.2 安装工作.....	22
9.3 电气连接.....	23
10 运行条件.....	23
11 投入使用和功能.....	23

11.1 概述.....	24
11.2 操作显示器.....	24
11.3 启动测试模式.....	24
11.4 门触点.....	24
11.5 设备故障.....	25
12 参数查看与设置.....	25
13 清洁和维护.....	26
13.1 清洁.....	26
13.2 维护.....	26
14 停止使用.....	27
15 故障排除.....	27
16 保障条款.....	27
附表 I.....	28
1 Hints on the manual.....	29
2 Handling.....	29
2.1 Transport.....	29
2.2 Storage.....	29
2.3 Unpacking.....	30
3 Scope of delivery and options.....	30
4 General Information.....	30
5 Name plate.....	30
6 Safety.....	31
7 Function.....	31
7.1 Function and configuration.....	31
7.2 Operating principles.....	32
7.3 Condensate.....	32

8	Technical data	33
8.1	Circuit Diagram.....	33
8.2	Spare parts	34
8.3	Installation Cut-out.....	34
8.4	Airflow principle	38
8.5	Technical Data	38
9	Installations	45
9.1	General.....	45
9.3	Electrical connection.....	46
10	Operating condition.....	47
11	Putting into operation and function	47
11.1	General remarks	47
11.2	Operation display	47
11.3	Start-up / Test mode	48
11.4	Door contact	48
11.5	Equipment fault	48
12	Parameters View and Settings	49
13	Cleaning and Maintenance.....	50
13.1	Cleaning	50
13.2	Maintenance	50
14	When not in used	50
15	Trouble shooting.....	51
16	Warranty Conditions.....	51
	Appendix I.....	52



请在安装机组前完整仔细阅读此手册。
本手册构成标准产品不可分割的一部分，必须保存至机组报废为止

1 手册提示

此手册为百能堡电气科技有限公司（以下简称百能堡）提供的门装或侧装螺栓固定，外挂式机柜空调系列的安装运行指南。

本手册中，安全提示和其他信息以下形式出现：



警告

如果没有严格遵守所述的措施，将有生命危险或造成健康危害。



危险

如果没有严格遵守所述的措施，将可能因电击造成生命或健康危害。



注意

如果没有严格遵守所述的措施，将有可能造成生命财物损失。

提示

提示包含关于所述措施或指导的额外信息。

2 搬运

2.1 运输

- 只能通过壳体或吊环来提升机柜空调（M8吊环不在供货范围）。
- 运输时保持机柜空调处于最终使用时相同的摆放状态。
- 如果整体机柜需要运输，请在运输前将机柜空调拆下并单独包装。

不按照这些指导操作，将导致保障条款失效。

2.2 储运

- 储存环境不应超过70°C。
- 储存时使机组处于最终使用时的摆放状态。

不按照这些指导操作，将导致保障条款失效。

2.3 开箱

开箱过程中应当仔细查看机柜空调，看是否存在因运输造成的破坏，尤其注意是否有部件松动、凹坑、擦伤和漏油等。任何损坏应当立即通知承运商（[见保障条款](#)），并且适用“百能堡产品售后服务声明”的最新版本。

- 在处理包装材料前，务必确认里面没有任何附加部件。



机组的钣金件边缘有可能残留金属毛刺，在维护或安装时务必带保护手套。
要求保障时，需要提供故障的确切信息（如有可能请提供照片），机种型号和序列号。

3 供货范围

供货范围包括：

- 机柜空调
- 附件包（包括紧固件，插头式电气连接器等）
- 特殊的附件（如适用）

4 一般信息

- 百能堡可以妥善处理旧设备,但客户需承担运输费用.
- 百能堡生产的机柜空调不含以下物质:
 - 多氯三联苯
 - 石棉
 - 甲醛
 - 镉
 - 液态有害物质
- 对每台机柜空调进行检查以确保它是完全依照9.ProdSV的规定（德国事故预防法规）。
- 交货前百能堡已对每台空调在工厂进行电气安全检测。

5 铭牌

安装和维护，请注意机器背部铭牌标注的详细技术信息。

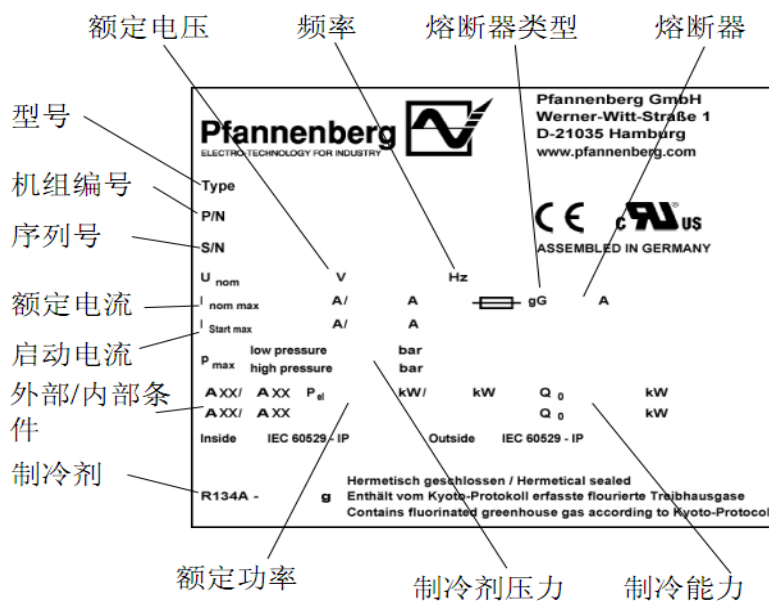

6 安全

- 由百能堡生产的机柜空调是专为机柜散热（IP54）而设计的。
- 该设备只适合在固定地点平稳运行。
- 任何其他使用范围被视为非授权使用，并将不作保修承诺。电气设备应定期检查。任何异常如连接松脱或烧焦的电缆必须被立即修复。
- 只有专业技术人员才能对热交换系统和电气部件进行操作。
- 请务必遵守相应的安全和环保法规。



危险

任何清洁或维护操作之前，需切断机柜空调电源。
只有原厂备件可以使用。

7 功能

7.1 配置与功能

- 1) +15°C~+55°C 外部环境温度
- 2) 内部控制温度 +25°C~+45°C
- 3) 冷凝水蒸发器（可选）
- 4) IP54/IP34防护
- 5) 2~400V交流供电（可选）

机柜冷却器有5度回差，即当内部设定温度为35°C，设备将在内部温度30°C以下时停止制冷。



注意

机柜空调的具体功能见技术规格书（[见章节8](#)）。

7.2 工作原理

压缩机（1）将制冷剂压缩到高压。在这个过程中温度升高。冷凝器（2）中，热量散失到周围环境空气中，制冷剂变成液体。冷凝器风扇（5）吸入并使空气通过冷凝器，然后排放出去。在截流装置（3）中，冷却液的压力下降。在蒸发器（4）中，冷却剂吸收机柜内空气中的热量并蒸发。因此，来自机柜中的空气被冷却下来；同时机柜内的空气被除湿。蒸发器风（6）吸出机柜内的空气并迫使其通过蒸发器，冷却空气吹回到机柜内。机柜空调是由电子系统控制的。温度传感器（7）记录了机柜内的空气温度。所使用制冷剂不损害臭氧层，而且不可燃。

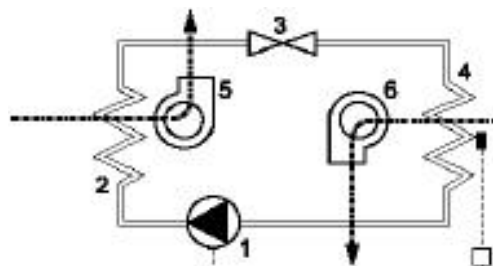

7.3 冷凝物

在蒸发器上发生的冷却过程中，空气中的水分被凝聚成冷凝水。为了避免对电控柜及本制冷系统发生任何损害，必须排出冷凝水。

冷凝水排放方式如下：

- 带冷凝水蒸发器（可选）的制冷设备在正常情况下，可以蒸发掉水分。但为防止蒸发器故障后产生的冷凝水溢流，请连接冷凝水管路，然后再通过水管排出。始终确保冷凝水正确地排出。在特定情况下有可能会发生凝结水过量，例如，机柜不密封或机柜内部温度经常低于露点温度。



注意

在正常运行过程中发生冷凝水过量，请检查机柜的密封。

我们建议安装一个门接触开关，当机柜门被打开时，机柜空调将自动关闭，以防止过度冷凝水。

8 技术规格书

8.1 电气原理图

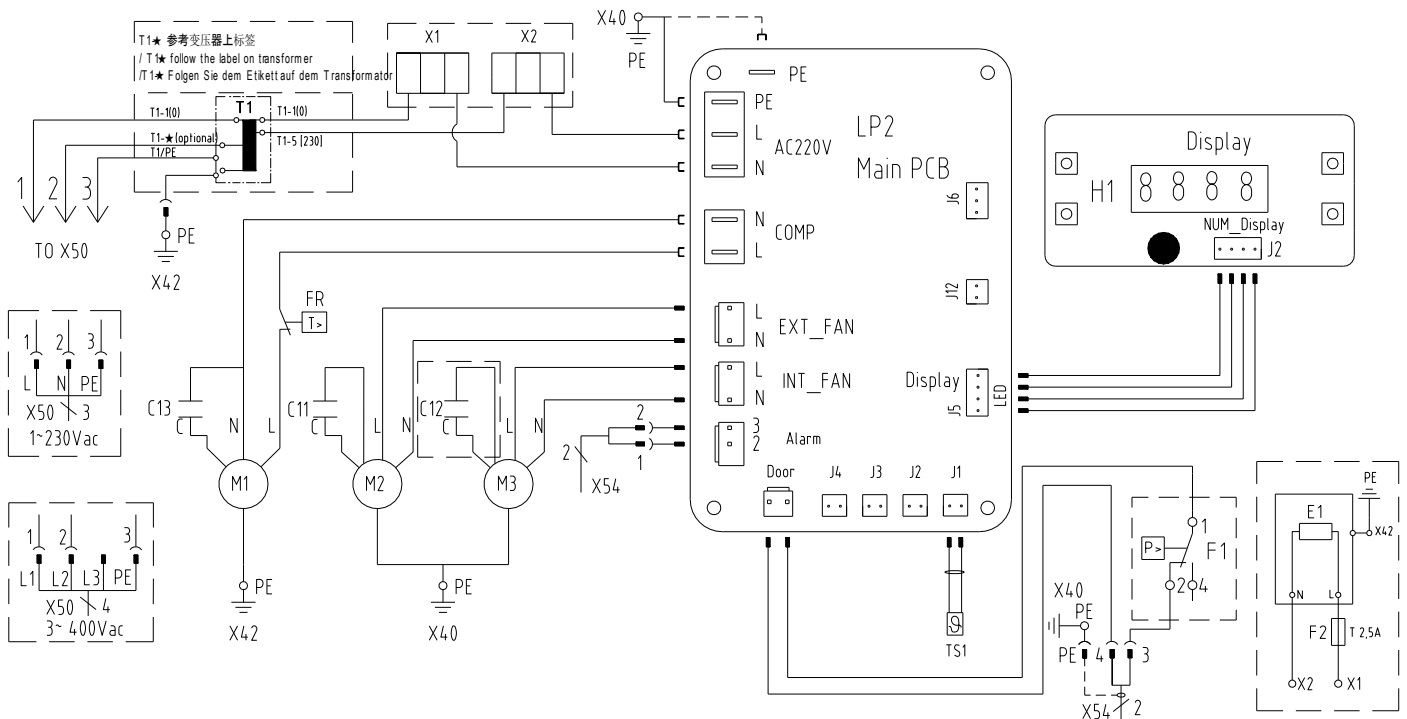

C11 电容- 冷凝器风扇
 C12 电容- 蒸发器风扇
 C13 电容- 压缩机
 E1 冷凝水蒸发器
 F2 熔断器
 FR 热保护器
 H1 指示器
 LP2 线路板
 F1 高压开关

M1 压缩机
 M2 冷凝器风扇
 M3 蒸发器风扇
 TS1 温度探头
 X1/X2 短接端子
 X40/X42 接地
 X50 电源连接
 X54 故障信号触点+门禁
 [] 可选

8.2 备品备件

(请使用百能堡物料号来采购备用件)

备用件	8031E	8241E	8341E	8441E	8541E
内风机	18861100017	18861100019	18861100020	18861100020	18861100022
外风机	18861100018	18861100020	18861100020	18861100021	18861100022
外壳 (RAL7035)	18860200014	18860200015	18860200015	18860200016	18860200016
外壳 (VAH)	18860200018	18860200019	18860200019	18860200020	18860200021
压缩机	18861200003	18861200001	18861200001	18861200004	18861200005
内风机电容	18864000004	18864000006	18864000002	18864000002	18864000007
外风机电容	18864000001	18864000002	18864000002	18864000000	18864000007
压缩机电容	18864000009	18864000011	18864000011	18864000011	18864000010
过滤干燥器	18865000002	18865000002	18865000002	18865000002	18865000002
控制器	物料号位于控制器上				

8.3 安装开孔

DTS 8021E

密封泡棉粘贴效果图

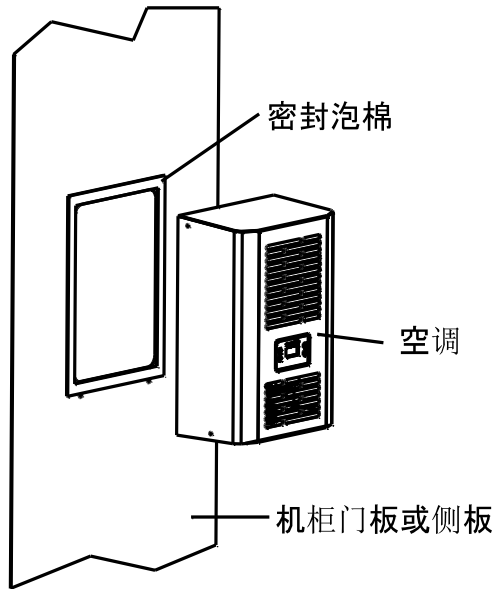

开孔尺寸

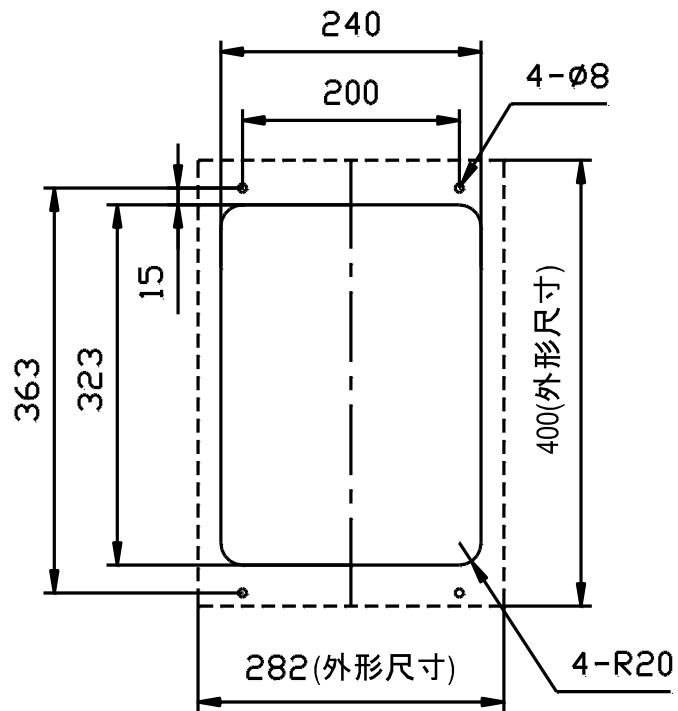

DTS 8031E

密封泡棉粘贴爆炸图

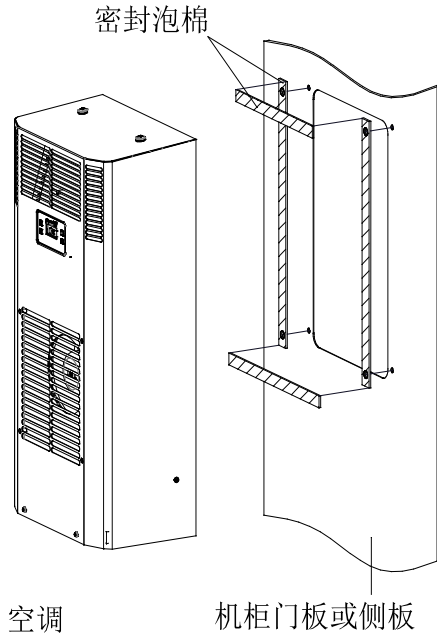

密封泡棉粘贴效果图

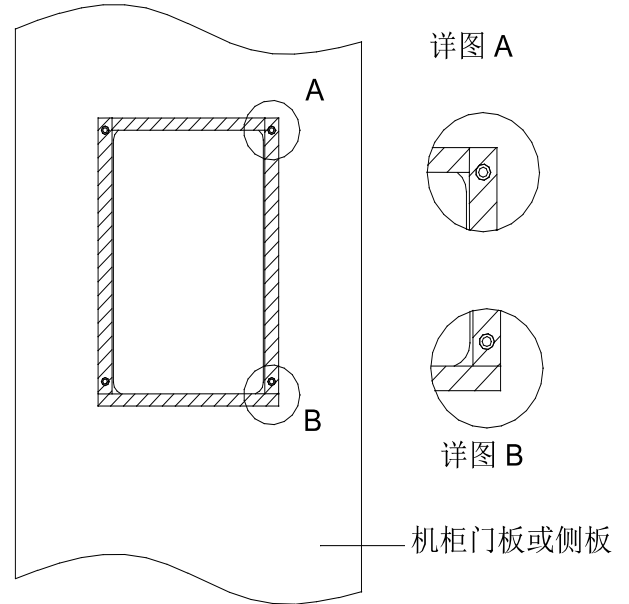

开孔尺寸

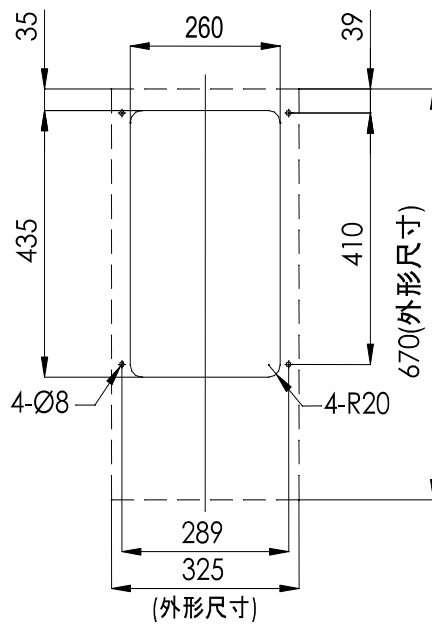

DTS 8241E/8341E/8441E/8541E

密封泡棉粘贴爆炸图

密封泡棉粘贴效果图

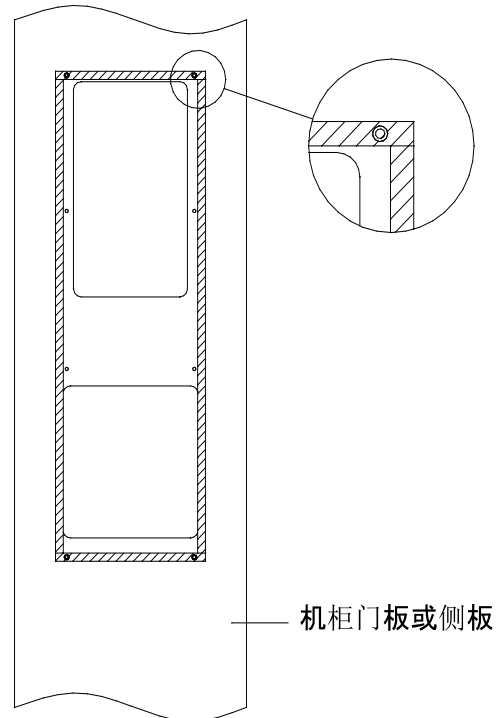
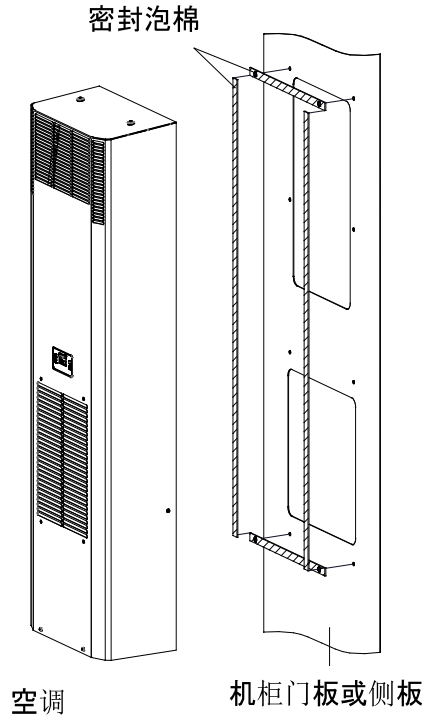

开孔尺寸

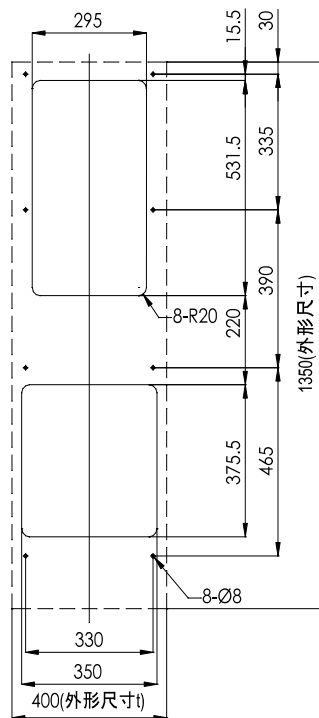

8.4 气流原理

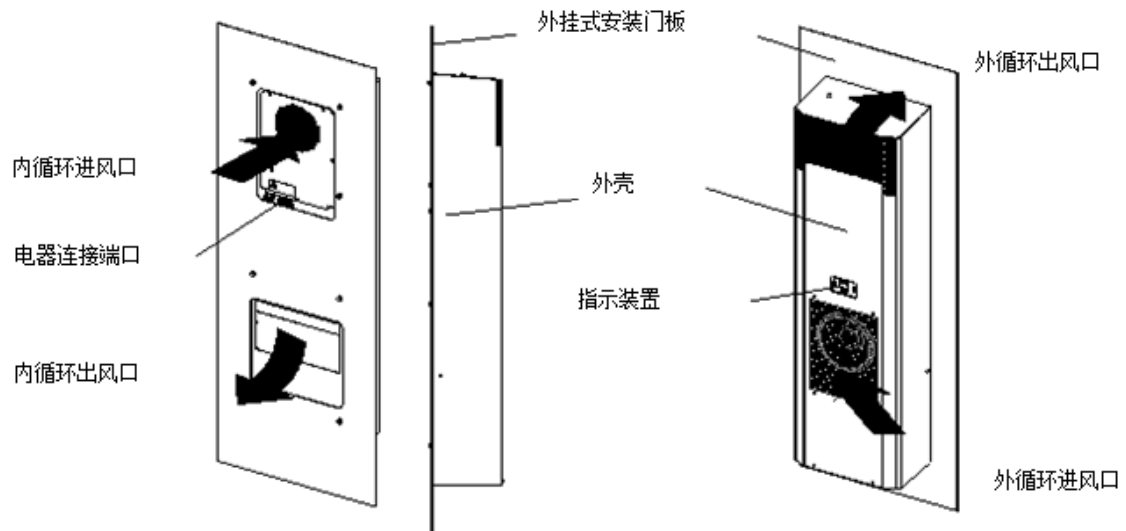

⚠ 注意

在安装此设备前应当完整仔细地阅读此说明。此说明是设备不可分割的一部分，在设备报废前请务必保留。
安装前，请确认设备间以及设备至墙体的距离至少有 200 毫米的间距；在柜子内部的进风口以及出风口没有干涉以及障碍。

8.5 技术参数

性能		DTS 8021E	
制冷能力 A35/A35 * **	Q _o	300 W	
制冷能力 A50/A35 * **	Q _o	150 W	
冷媒*		R 134a	
冷媒量*		120 g	
温控 (工厂设置)		+35° C (+95° F)	
内部温度报警指示 (工厂设置)		> +50° C (+122° F)	
环境温度		+15° C (+59° F) . . . +55° C (+131° F)	
内部温度		+25° C (+77° F) . . . +45° C (+113° F)	
外循环气流量 °)		282 m ³ /h	
内循环气流量 °)		224 m ³ /h	
冷凝水排放		冷凝排水管	
噪音 (1m)		≤ 62 dB(A)	
电气数据			
电源频率		50 Hz	
工作范围		DIN IEC 60038	
额定电压		230 V	
电力消耗 *(A35/A35) :	P _{el}	285 W	
电流 *	I _{nom max}	1.7 A	
启动电流 *	I _{Start max}	3.0 A	
尺寸			
高 X 宽 X 深 ° °)		400 X 282 X 160 (mm)	
重量		11.5 kg	
安装状态		垂直	
结构		标准: 钢板 可选: 不锈钢	
防腐处理		标准: 镀锌, 静电喷粉 (200° C) 可选: 不锈钢, 铝	
防护等级		IP 54 对机柜 (EN 60529), 正确安装操作为前提 IP 34 对环境 (EN 60529), 正确安装操作为前提, 需安装前外壳	

性能		DTS 8031E	
制冷能力 A35/A35 * **	Q _o	500 W	
制冷能力 A50/A35 * **	Q _o	330 W	
冷媒*		R 134a	
冷媒量*		190 g	
温控 (工厂设置)		+35° C (+95° F)	
内部温度报警指示 (工厂设置)		> +50° C (+122° F)	
环境温度		+15° C (+59° F) . . . +55° C (+131° F)	
内部温度		+25° C (+77° F) . . . +45° C (+113° F)	
外循环气流量 (°)		590 m ³ /h	
内循环气流量 (°)		275 m ³ /h	
冷凝水排放		冷凝水管. (可选: 冷凝水蒸发器)	
噪音 (1m)		≤ 63 dB(A)	
电气数据			
电源频率		50 Hz	
工作范围		DIN IEC 60038	
额定电压		230 V	400 V
电力消耗 *(A35/A35) :	P _{el}	289 W	358 W
电流 *	I _{nom max}	1.7 A	1.58 A
启动电流 *	I _{Start max}	3.5 A	3.5 A
冷凝水蒸发器 (CM)	P _{el}	可选 30-110W (A35/A35 ca. 70W)	
尺寸			
高 X 宽 X 深 (°)		670 X 325 X 200 (mm)	
重量		17.3 kg	25.3 kg
冷凝水蒸发器重量		可选: 0.5kg	
安装状态		垂直	
结构		标准: 钢板 可选: 不锈钢	
防腐处理		标准: 镀锌, 静电喷粉 (200° C) 可选: 不锈钢, 铝	
防护等级		IP 54 对机柜 (EN 60529), 正确安装操作为前提 IP 34 对环境 (EN 60529), 正确安装操作为前提, 需安装前外壳	

性能		DTS 8241E	
制冷能力 A35/A35 * **	Q _o	1000 W	
制冷能力 A50/A35 * **	Q _o	840 W	
冷媒 *		R 134a	
冷媒量*		430 g	
温控 (工厂设置)		+35° C (+95° F)	
内部温度报警指示 (工厂设置)		> +50° C (+122° F)	
环境温度		+15° C (+59° F) . . . +55° C (+131° F)	
内部温度		+25° C (+77° F) . . . +45° C (+113° F)	
外循环气流量 °)		1000 m ³ /h	
内循环气流量 °)		570 m ³ /h	
冷凝水排放		冷凝水管. (可选: 冷凝水蒸发器)	
噪音 (1m)		≤ 65 dB(A)	
电气数据			
电源频率		50 Hz	
工作范围		DIN IEC 60038	
额定电压		230 V	400 V
电力消耗 *(A35/A35) :	P _{el}	513 W	589 W
电流 *	I _{nom max}	3.1 A	2.25 A
启动电流 *	I _{Start max}	10.5 A	10.5 A
冷凝水蒸发器 (CM)	P _{el}	可选: 30-110W (A35/A35 ca. 70W)	
尺寸			
高 X 宽 X 深 ° °)		1350 X 400 X 200 (mm)	
重量		33.5 kg	41.2 kg
冷凝水蒸发器重量		可选: 0.5kg	
安装状态		垂直	
结构		标准: 钢板 可选: 不锈钢	
防腐处理		标准: 镀锌, 静电喷粉 (200° C) 可选: 不锈钢, 铝	
防护等级		IP 54 对机柜 (EN 60529), 正确安装操作为前提 IP 34 对环境 (EN 60529), 正确安装操作为前提, 需安装前外壳	

性能		DTS 8341E	
制冷能力 * **	Q _o	1500 W	
制冷能力 * **	Q _o	900 W	
冷媒 *		R 134a	
冷媒量 *		430 g	
温控 (工厂设置)		+35° C (+95° F)	
内部温度报警指示 (工厂设置)		> +50° C (+122° F)	
环境温度		+15° C (+59° F) . . . +55° C (+131° F)	
内部温度		+25° C (+77° F) . . . +45° C (+113° F)	
外循环气流量 (°)		1000 m ³ /h	
内循环气流量 (°)		1000 m ³ /h	
冷凝水排放		冷凝水管 (可选: 冷凝水蒸发器)	
噪音 (1m)		≤ 65 dB(A)	
电气数据			
电源频率		50 Hz	
工作范围		DIN IEC 60038	
额定电压		230 V	400 V
电力消耗 *(A35/A35) :	P _{el}	596 W	632 W
电流 *	I _{nom max}	3.48 A	2.45 A
启动电流 *	I _{Start max}	11 A	11 A
冷凝水蒸发器 (CM)	P _{el}	可选: 30-110W (A35/A35 ca. 70W)	
尺寸			
高 X 宽 X 深 (° °)		1350 X 400 X 200 (mm)	
重量		34.1 kg	41.8 kg
冷凝水蒸发器重量		可选: 0.5kg	
安装状态		垂直	
结构		标准: 钢板 可选: 不锈钢	
防腐处理		标准: 镀锌, 静电喷粉 (200° C) 可选: 不锈钢, 铝	
防护等级		IP 54 对机柜 (EN 60529), 正确安装操作为前提 IP 34 对环境 (EN 60529), 正确安装操作为前提, 需安装前外壳	

性能		DTS 8441E	
制冷能力 A35/A35 * **	Q _o	2000 W	
制冷能力 A50/A35 * **	Q _o	1400 W	
冷媒*		R 134a	
冷媒量*		850 g	
温控 (工厂设置)		+35° C (+95° F)	
内部温度报警指示 (工厂设置)		> +50° C (+122° F)	
环境温度		+15° C (+59° F) . . . +55° C (+131° F)	
内部温度		+25° C (+77° F) . . . +45° C (+113° F)	
外循环气流量 (°)		1340 m ³ /h	
内循环气流量 (°)		1000 m ³ /h	
冷凝水排放		冷凝水管 (可选: 冷凝水蒸发器)	
噪音 (1m)		≤ 66 dB(A)	
电气数据			
电源频率		50 Hz	
工作范围		DIN IEC 60038	
额定电压		230 V	400 V
电力消耗 *(A35/A35) :	P _{el}	734 W	784 W
电流 *	I _{nom max}	5.8 A	5.1 A
启动电流 *	I _{Start max}	15 A	15 A
冷凝水蒸发器 (CM)	P _{el}	可选: 30-110W (A35/A35 ca. 70W)	
尺寸			
高 X 宽 X 深 (° °)		1350 X 400 X 230 (mm)	
重量		43 kg	50.7 kg
冷凝水蒸发器重量		可选: 0.5kg	
安装状态		垂直	
结构		标准: 钢板 可选: 不锈钢	
防腐处理		标准: 镀锌, 静电喷粉 (200° C) 可选: 不锈钢, 铝	
防护等级		IP 54 对机柜 (EN 60529), 正确安装操作为前提 IP 34 对环境 (EN 60529), 正确安装操作为前提, 需安装前外壳	

性能		DTS 8541E	
制冷能力 A35/A35 * **	Q _o	2500 W	
制冷能力 A50/A35 * **	Q _o	1800 W	
冷媒 *		R 134a	
冷媒量*		760 g	
温控 (工厂设置)		+35° C (+95° F)	
内部温度报警指示 (工厂设置)		> +50° C (+122° F)	
环境温度		+15° C (+59° F) . . . +55° C (+131° F)	
内部温度		+25° C (+77° F) . . . +45° C (+113° F)	
外循环气流量 °)		1490 m ³ /h	
内循环气流量 °)		1490 m ³ /h	
冷凝水排放		冷凝水管 (可选: 冷凝水蒸发器)	
噪音 (1m)		≤ 67 dB(A)	
电气数据			
电源频率		50 Hz	
工作范围		DIN IEC 60038	
额定电压		230 V	400 V
电力消耗 *(A35/A35) :	P _{el}	1068 W	1089 W
电流 *	I _{nom max}	7.9 A	7.0 A
启动电流 *	I _{Start max}	18.4 A	18.4 A
冷凝水蒸发器 (CM)	P _{el}	可选: 30-110W (A35/A35 ca. 70W)	
尺寸			
高 X 宽 X 深 ° °)		1350 X 400 X 230 (mm)	
重量		49.3 kg	62.7 kg
冷凝水蒸发器重量		可选: 0.5kg	
安装状态		垂直	
结构		标准: 钢板 可选: 不锈钢	
防腐处理		标准: 镀锌, 静电喷粉(200° C) 可选: 不锈钢, 铝	
防护等级		IP 54 对机柜 (EN 60529), 正确安装操作为前提 IP 34 对环境 (EN 60529), 正确安装操作为前提, 需安装前外壳	

* 铭牌信息,**无过滤网(可选)情况下制冷量

°)自由送风, °°)空调电器接口处另需电器端子空间 40mm

9 安装

9.1 概述

- 正确选择机柜空调在机柜上的安装位置,保证良好的通风。
- 机柜空调之间或是机柜空调和墙壁的距离必须保证至少200毫米。
- 在机柜内部, 空调的电器连接端子处需预留至少40mm空间.
- 在机柜内部, 电气元件不得阻碍空气循环。
- 机柜空调在安装时, 机柜空调的电源必须断开!
- 安装现场必须受到保护, 免遭污染。

⚠ 注意

如果机柜空调是装在机柜门上, 必须检查门的铰链能够支持机柜空调的重量或当门被打开机柜时, 不会翻倒。

⚠ 注意

金属碎屑可能损坏机柜。如果在安装现场开安装孔, 确保使用保护罩, 以免切屑进入机柜, 损坏电气元件。

提示

为方便机柜空调安装, M8的吊环可以旋入机柜空调顶部固定, 方便吊装, 简单“一人安装”就能实现。

9.2 安装工作

机柜安装面要开好空气通风口和螺栓安装固定孔, 尺寸根据开孔尺寸。

- 1) 如机柜未预留机柜空调的开口, 在机柜上切出开口(尺寸见[开孔尺寸](#)), 然后去除剪边毛刺。
- 2) 取出附件包内密封条(标号8,9或10,11,12)贴在门板外侧(如图)。先将密封条8或11上的孔与门板圆孔同心 后再按压在门板上, 然后将密封条9或10或12外边线与8或11外边线对齐后贴在门板上。
- 3) 在机柜内侧, 取出附件包内的螺栓、平垫片、弹垫、螺母及螺栓(标号3,4,5,6,7)将空调锁紧。
- 4) 将出水管通过机柜空调底板, 使冷凝水能自由流下, 并将水管切至所需长度。

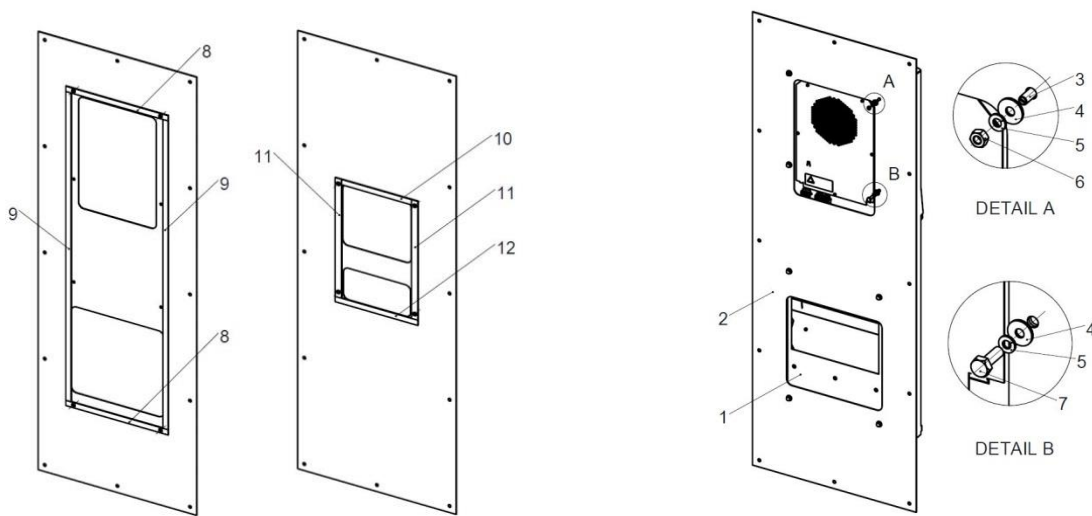

- 1 机柜空调组
- 2 机柜侧板或机柜门

- 5 弹簧垫片
- 6 螺母

- | | |
|-------|------------------|
| 3 牙棒 | 7 螺栓 |
| 4 平垫片 | 8,9,10,11,12 密封条 |

- 5) 如果机柜空调在安装时拆下外壳顶部的M8螺母，需将其安装好。
- 6) 将电线按照接线图（见机柜空调背部）连接到连接头（附件包中），并连接到机柜空调。- 导线尺寸：1.0 – 2.5平方毫米或AWG18 - AWG14（在电缆的大小选择，应参照相关法规要求！）
- 7) 将机柜空调插上电源（见9.3）
- 8) 不同机器可能安装方式不同，请参考随机资料。

9.3 电气连接

⚠ 注意

- 机柜空调应当经由断路器连接到电源（请选择合适的断路器），断开断路装置时,其触点间隙应不少于3毫米。
- 电源线上不可以串接温度传感器。
- 电源线上需要串接铭牌注明的保险丝,作为线路保护。
- 电源连接和维修，如果适用，只能由授权的经过培训的电工来进行。

电源连接：

电源电压和频率必须符合铭牌标示值。请认真看机器上有更多带有解释的标签。

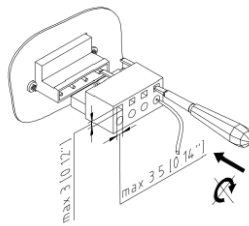

⚠ 注意

如果电压过高可能会导致器件损坏。
一般空调的额定电压230V或400V。

10 运行条件

- 电压范围为额定电压的 $\pm 10\%$ 以内。
- 电源频率为额定频率的 $\pm 3\text{Hz}$ 以内。
- 环境温度必须低于 55°C 。
- 使用本机时注意使热交换量适合实际的需求。
- 只使用原装备件。

11 投入使用和功能

- 机柜空调包含的功能及可选项见[章节 7](#)。

11.1 概述

- 机柜空调配有温度控制系统。机柜内部温度通过温度传感器来测量。通过操作显示器可以设定不同的机柜内温度（见附表I）。
- 机柜空调具有上电检测、运行时实时监测功能。上电检测过程中如果有故障，空调会发出相应的报警，这使得在进入工作模式之前更方便的排查设备故障。



警告

机柜空调只能在装有前盖的情况下运行，否则会因散热不良造成机柜空调被损坏。

11.2 操作显示器

机柜空调装有操作显示器。上电后操作显示器显示0.0°C,1S后显示柜内实时温度，表明机组在正常操作模式。如果发生故障或有报警输出时，操作显示器显示报警代码，警报灯点亮并伴随报警声，这使诊断机柜空调故障更容易（见章节15）。

11.3 启动测试模式

通电前，若门触点断开，则机柜空调不启动，直到门触点闭合后，机柜空调进入自测试模式,自测试模式将不受外部环境影响。机柜空调运行启动模式持续3秒，之后是测试模式持续约110秒。测试模式时，有故障设备继续运行，直到测试模式结束，产生相应的报警代码，如有故障则需解除故障后进入正常工作模式，如无故障，直接进入正常工作模式。

模式	时间曲线	特征
启动模式	t=0s-1s	无功能，操作显示器显示“0.0°C”
	t=1s-3s	显示内部温度
测试模式	t=4s-13s	内风机运行
	t=14s-23s	外风机运行
	t=24s-53s	内风机停止 压缩机运行
	t=54s-115s	外风机停止 内风机、外风机、压缩机一起运行

11.4 门触点

确保安全门限位开关应连接到指定端口（见机壳上线路图或[电气原理图](#)）当打开机柜门时门触开关即被断开，机柜空调所有马达延时依次关闭，之后产生报警。

注意

为了避免任何破坏性的影响，建议使用一根带护线套的双绞线电缆。
 无需另接外部电源。
 如果门触点开关未被使用，需将其短接（位置见机壳标签或[电气原理图](#)）

11.5 设备故障

机柜空调故障触点X54—1,2脚为常闭触点，上电后无故障为闭合，有故障时将引起故障触点断开并显示告警代码(见[章节15](#))。

注意

故障指示连接最大容量为：230V，1A

12 参数查看与设置

机柜空调可以通过操作显示器对参数进行监控或设置。

- 机柜空调电子控制系统包括主控制系统、操作显示系统。面板上的指示灯从左到右排列的功能含义如下表：

指示灯	指示灯含义	长亮	备注
	上电自检	自检	启用
	制冷	正在制冷	启用
	制热	-----	无
	除湿	-----	无
	外风机	风机运转	启用
	告警	告警发生	启用

操作面板



1. 参数查看

为方便排除故障，主界面下按“Select”键 3S，进入界面“SEE”，再按“Select”键确认进入，按“▲”或“▼”键可循环选择柜内回风温度“Pb1”、空调启动温度“t1”、门禁开关状态“dor”、内风机运行状态“IFR”、外风机运行状态“EFR”、压缩机运行状态“Con”、报警输出状态“ALr”，在任意一个参数代码界面按“Select”键，显示相应参数的参数值，按“Mode”键返回上层菜单或者静置 5min 自动返回主界面。
 具体代码意义详见（[附表1](#)）。

2. 参数设置

内部目标温度可以设置，主界面下按“Select”键 3S，进入界面“SEE”，再按“Select”键确认进入后，通过“▲”

“▼”键选择“t1”，再按“Select”键显示具体参数值，长按“▲”键6S后即可调整参数值的大小，调整到正确的数值后再按“Select”键确认修改，然后按“Mode”键返回上层菜单或者静置5min自动返回主界面。如果不需要修改，直接按“Mode”键返回上层菜单即可。

注意

只有“t1”可以设置，即机柜内设定温度；其他参数只用于排除故障参考。

注意

任何画面下，无任何按键触发300秒后返回主画面。
参数修改成功后需要返回主界面，修改值才会生效。

13 清洁和维护

危险

在任何清洁或维护操作前，请切断空调电源。

13.1 清洁

建议每个月对机柜空调进行维护，例如对冷凝回路进行清洗，将提高设备的运转效率以及可靠性。具体维护周期视使用环境而定。

特别注意以下说明：

- 清洗外部风道，冷凝器以及外风机。
- 用软刷或高压空气进行作业。（注意不要伤到翅片）

步骤如下：

- 1) 断开机柜空调电源。
- 2) 打开外壳。
- 3) 清洁风道。
- 4) 清洁外风机。
- 5) 清洁交换器。
- 6) 装回外壳
- 7) 接通电源并观察上电自检，确保设备运转正常。

注意

防止电气元件漏电。不要使用任何尖锐或锋利的物体。

防止热交换器损坏。

防止外罩电气连接损坏。在拆卸外罩时，应当手动拔去外罩里面的电气连接。安装时，不要忘插上该电气连接！

13.2 维护

设备出现故障后，会自动提示故障代码，主要故障代码对应的故障原因[见章节15](#)。

在每一次维护后，请等待设备上电自检结束，查看自检情况，以确保设备能够正常运转。

14 停止使用

如果机柜空调在较长时间内未被使用，请切断电源。确保未经授权的人员不会擅自启动空调。
机柜空调需要报废处理时，需根据相关环保法规由专业人员进行处理。（见章节 4）

15 故障排除

尽管有精心维护,还是有可能产生故障。机柜空调的实时自检功能能够准确的自行诊断设备故障。
如果机器发生故障，操作显示器显示相关报警代码，用户可根据下表中的报警代码查找，使得诊断更容易。

报警列表

报警代码	描述	故障排除方法
AL01	Pb1 报警	1) 检查感温头 Pb1; 2) 检查连接线是否损坏; 3) 检查接头是否插错位。
AL02	机柜门打开	1) 检查门开关; 2) 检查接线是否松动; 3) 检查接线是否接错。
AL03	超温告警	1) 查看是否 AL02 报警，此时设备停止工作; 2) 检查内外风机是否正常工作; 3) 检查压缩机是否正常工作; 4) 检查冷凝器是否脏堵; 5) 检查内部风口是否堵塞，风道是否顺畅; 6) 检查热负荷。



警告

非授权人员不可检修此设备

16 保障条款

以下情况保障将失效：

- 机组的不恰当使用，不适宜的运行条件或不遵守操作指导；
- 在腐蚀或酸性空气环境下使用；
- 由脏污或脏堵的过滤垫造成的损坏；
- 非授权人员擅动温度控制回路，改动机组或更改机组序列号；
- 由运输或是事故造成的损坏；
- 由非授权组织更换部件；

为了维护您的质保权益，在退回机组时请遵守以下规定：

- 在包装中附上确切的故障描述。
- 附上发货单（百能堡发货单或发票复印件）。
- 随机将所有附件退回；使用原始包装或同规格的包装，运输时先垫付运费及足够的运输保险。

遵守[章节 2](#)提到的运输提示

附表 I

显示参数（操作显示器）

参数	描述	最小值	最大值	默认值	单位
PB1	内循环回风温度（可测范围）	-30	60	-	°C
t1*	设定温度（可设定范围）	25	45	35	°C
Dor	门开关，0 代表门开关断开，1 代表门开关闭合	0	1	-	-
IFR	内风机，0 代表停止工作，1 代表正在工作	0	1	-	-
EFR	外风机，0 代表停止工作，1 代表正在工作	0	1	-	-
Con	压缩机，0 代表停止工作，1 代表正在工作	0	1	-	-
ALr	故障报警，0 代表有故障输出，1 代表无故障，设备正常工作	0	1	-	-
AL01	Pb1 报警，0 代表有故障，1 代表无故障	0	1	-	-
AL02	机柜门打开，0 代表有故障，1 代表无故障	0	1	-	-
AL03**	超温告警，0 代表有故障，1 代表无故障	0	1	-	-

* 为内部设定温度可修改设定值。

**当内部温度高于设定温度” t1” 上15度时设备将进行高温报警；产生高温告警后如果温度下降到设定温度“t1” 上的10度内，高温告警消失。



所有未提及参数请勿擅自更改，否则设备将不能正常



Read this manual completely and carefully before installing the unit. This manual is an integral part of the product and must be kept until is Disposed.

1 Hints on the manual

This handbook contains instructions for the installation and operation of door or side-mounted, bolt-on Cooling Units provided by Pfannenberg.

In this manual, safety recommendations and other information are structured as follows.



WARNING

If the measures described in the following are not strictly observed there is danger to life and health.



DANGER

If the measures described in the following are not strictly observed there is danger to life and health due to electrical shock.



CAUTION

If the measures described in the following are not strictly observed material damage may be caused.

NOTE

A hint contains additional information on the action or instruction described.

2 Handling

2.1 Transport

- Lift cooling unit only by the casing or with two eyebolt rings (M8 eyebolt rings are not in scope of delivery)
- Transport the cooling unit only in condition of usage.
- Prior to transport remove the cooling unit and pack it separately if the complete switch cabinet is to be transported.

Failure to observe these instructions will render the warranty provisions null and void.

2.2 Storage

- Never expose cooling units to temperatures exceeding +70 °C during storage.
- Store cooling unit only in condition of usage.

Failure to observe these instructions will render the warranty provisions null and void.

2.3 Unpacking

- During unpacking make a visual inspection of the cooling unit to see whether any damage has occurred during transport. Especially pay attention to loose parts, dents, scratches, visible loss of oil etc. Any damage must be reported immediately to the forwarding agent ([also refer to warranty](#)). Moreover, the latest edition of the "Pfannenberg After Sales Service Declaration" shall apply.
- Before disposing of packing material ensure that it does not contain any loose components.



Burr caused by production may be present on the metal edges of the unit. Always wear protective gloves when carrying out maintenance work and installation.

In case of a warranty claim exact details on the fault (photograph, if possible) and the indication of type and serial number of the cooling unit are required.

3 Scope of delivery and options

The Scope of delivery includes:

- Cooling unit
- Enclosed package (among other things, fastening material, electrical plug-type connectors)
- Quick guide
- Special accessories, if applicable

4 General Information

- Old devices can be properly disposed of by Pfannenberg. They must be sent to one of our works shipment/postage paid.
- All cooling units produced by Pfannenberg are free from
 - PCT
 - Asbestos
 - Formaldehyde
 - Cadmium
 - Substances impairing wetting.
- Every cooling unit is checked to ensure that it is tight according to the provisions of 9.ProdSV (German regulations covering accident prevention).
- Pfannenberg has done electrical safety testing to every cooling before delivery.

5 Name plate

For the installation and maintenance, please take note of the technical data on the name plate which can be found on the back of the cooling unit.

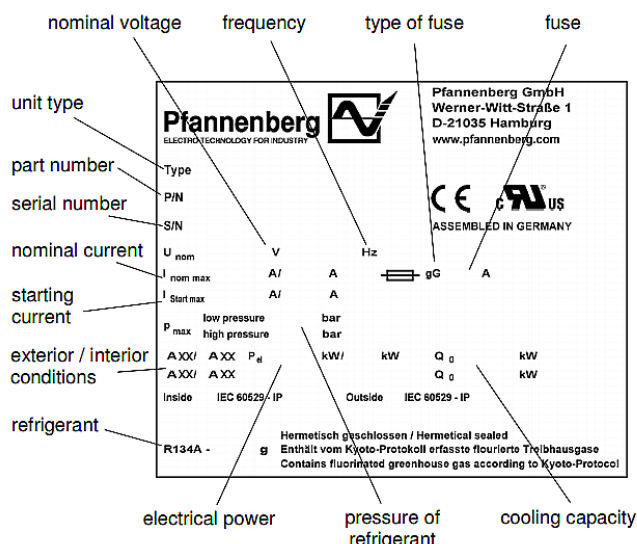

6 Safety

Cooling units produced by Pfannenberg are designed for use in dissipating heat from switch cabinets (IP 54).

The cooling unit is only suitable for installing on the stationary operation.

Only the authorized specialist can work on the cooling system and electrical components.

Please make sure to comply with relevant safety and environmental regulations.



Switch off cooling unit power supply before carrying out any cleaning or maintenance operations.

Only original spare parts may be used.

7 Function

7.1 Function and configuration

1. General external environment temperature: +15°C~+55°C
2. Internal temperature control range: +25°C~+45°C
3. IP54 internal / IP34 external protection class
4. Condensate evaporator (optional), for some model not available
5. 2~Phases 400Vac power supply (optional), for some model not available

The unit has a 5 °C hysteresis, means if setting temperature is 35 °C, the unit will stop cooling when internal temperature goes below 30°C. It has a fixed alarm differential temperature of 15°C.

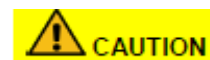

Please refer to technical data for the detailed function of the cooling unit.

7.2 Operating principles

The compressor (1) compresses the refrigerant until high pressure is achieved. During this process temperature increases. In the condenser (2) heat is dissipated to ambient air, the coolant becoming liquid. The condenser fan (5) takes ambient air in through the condenser, and then it releases the air. In the expansion valve (3) the pressure of the coolant drops. In the evaporator (4) the coolant absorbs heat from the air in the switch cabinet and evaporates. Thus, the air in the switch cabinet cools down. At the same time the air inside the switch cabinet is being dehumidified. The evaporator fan (6) sucks the air out of the switch cabinet via the evaporator, the cooled air flows back to the switch cabinet.

The cooling unit is electronically controlled. For that purpose a temperature sensor records the temperature of the air inside the switch cabinet (7).

The refrigerant is not detrimental to the ozoneosphere; it is hardly combustible.

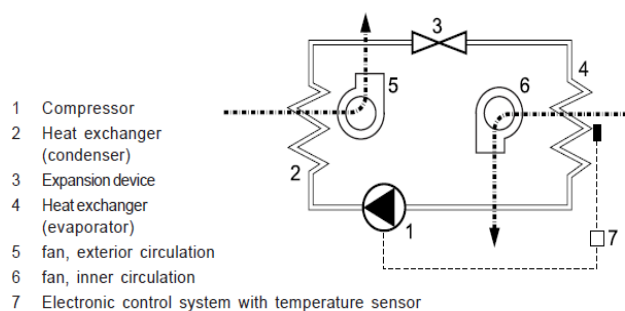

7.3 Condensate

During cooling, the moisture removed from the hot air by the evaporator is collected as condensate. In order to avoid any damage to the switch cabinet and the cooling unit, the condensate must be discharged.

The condensate is discharged in the following way:

In case of normal condensate drainage a reservoir (option) collects the condensate which is then drained by means of a hose.

Always ensure that the condensate is drained properly (safety- drainage).

Excessive condensation can occur if, for example, the switch cabinet is not sealed or if the internal temperature of the switch cabinet is frequently below the dew point.

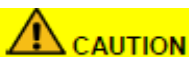

Please check the sealing of the switch cabinet, if there is excessive condensate during the normal operation.

In order to prevent the excessive condensate we recommend to install a door contact switch. It will switch off the cooling unit when the switch cabinet door is open.

8 Technical data

8.1 Circuit Diagram

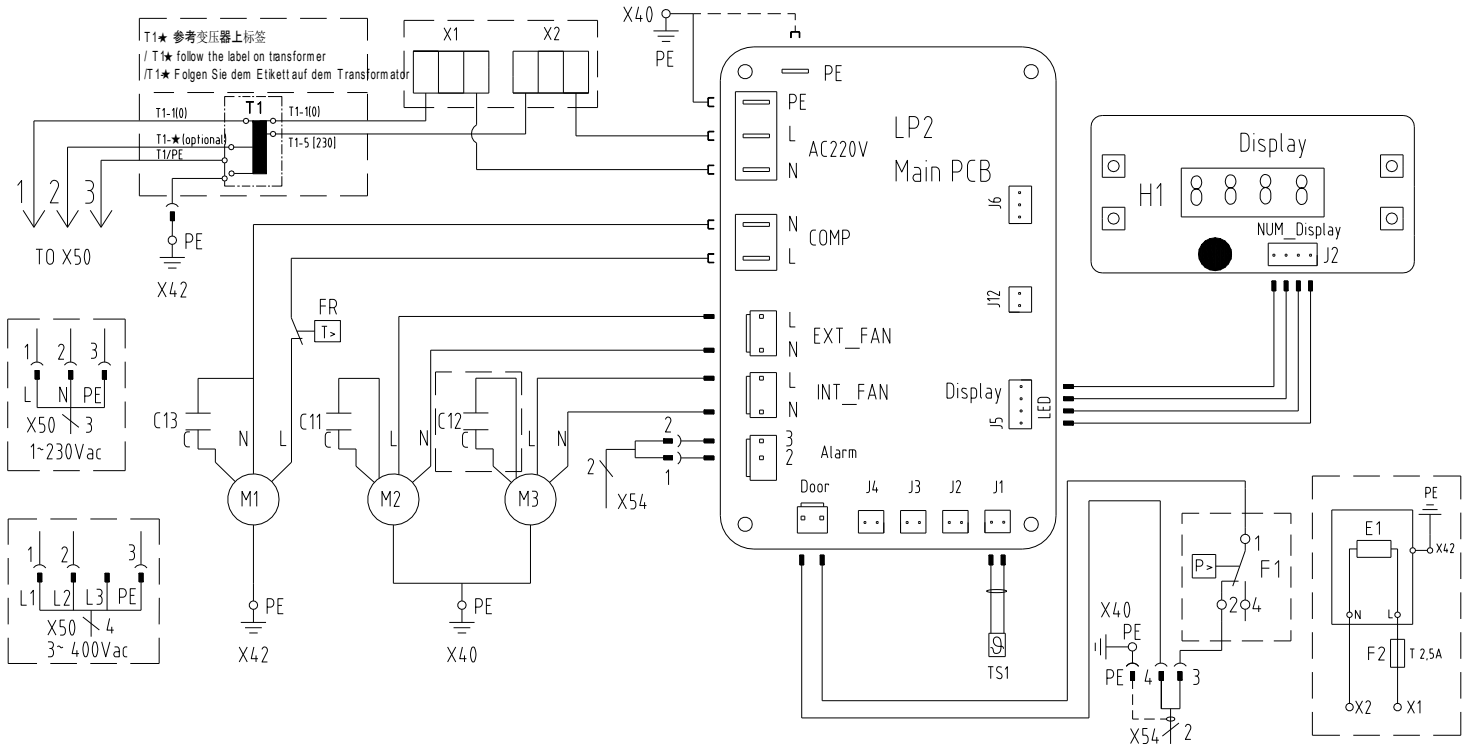

C11 Capacitors-condenser fan
 C12 Capacitors-evaporator fan
 C13 Capacitors-compressor
 E1 Condensate evaporation
 F2 Fuse
 FR Overheat protector
 H1 Operating indicator
 LP2 PCB
 F1 high pressurestat

M1 Compressor
 M2 Condenser fan
 M3 Evaporator fan
 TS1 Temperature sensor
 X1/X2 Sub terminal
 X40/X42 Earthing connection
 X50 Connection mains
 X54 Connection failure indication + door contact
 [] Option

8.2 Spare parts

Please order your spare parts only with the Pfannenberg-parts-number.

Spare parts	8031E	8241E	8341E	8441E	8541E
Internal fan	18861100017	18861100019	18861100020	18861100020	18861100022
External fan	18861100018	18861100020	18861100020	18861100021	18861100022
Cover(RAL7035)	18860200014	18860200015	18860200015	18860200016	18860200016
Cover(VAH)	18860200018	18860200019	18860200019	18860200020	18860200021
Compressor	18861200003	18861200001	18861200001	18861200004	18861200005
Internal fan Capacitor	18864000004	18864000006	18864000002	18864000002	18864000007
External fanCapacitor	18864000001	18864000002	18864000002	18864000000	18864000007
CompressorCapacitor	18864000009	18864000011	18864000011	18864000011	18864000010
Filter Dryer	18865000002	18865000002	18865000002	18865000002	18865000002
Controller	Part number is located on the controller				

8.3 Installation Cut-out

DTS 8021E

Effect view of the sealing

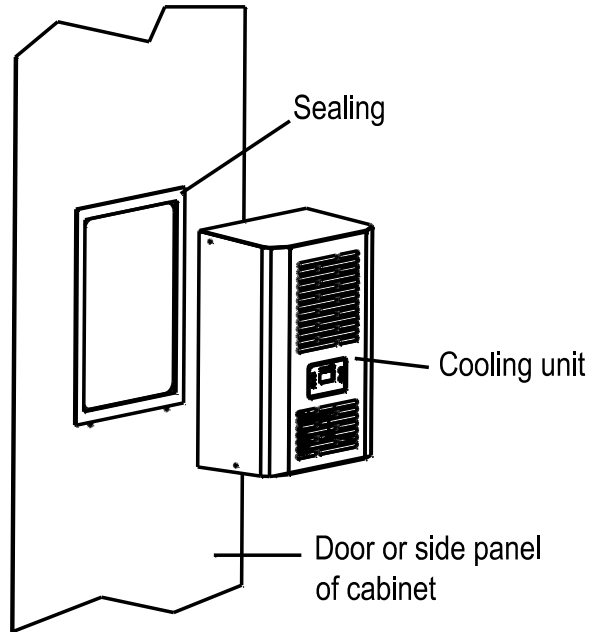

Cut out Dimension

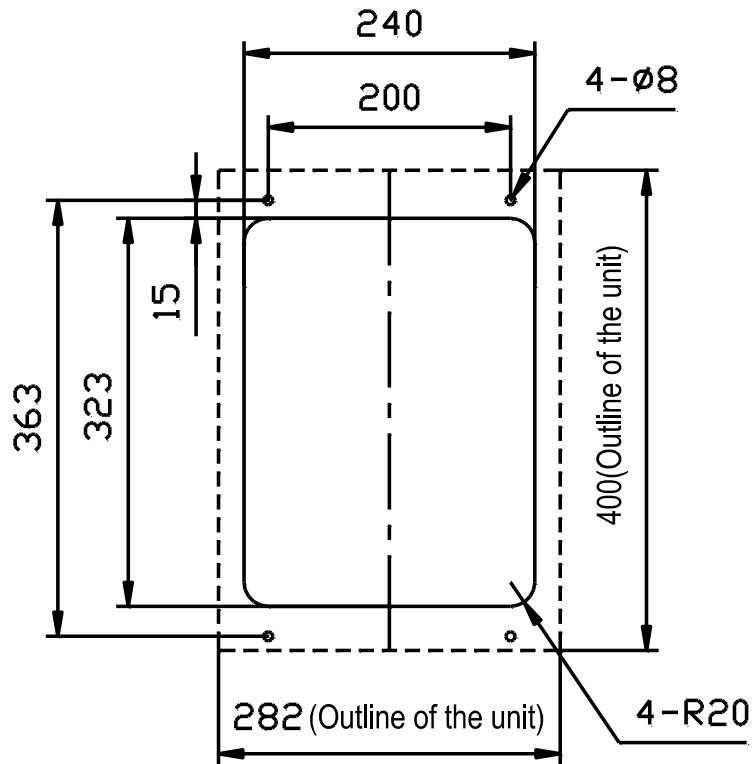

DTS 8031E

Explosive view of the sealing

Effect view of the sealing

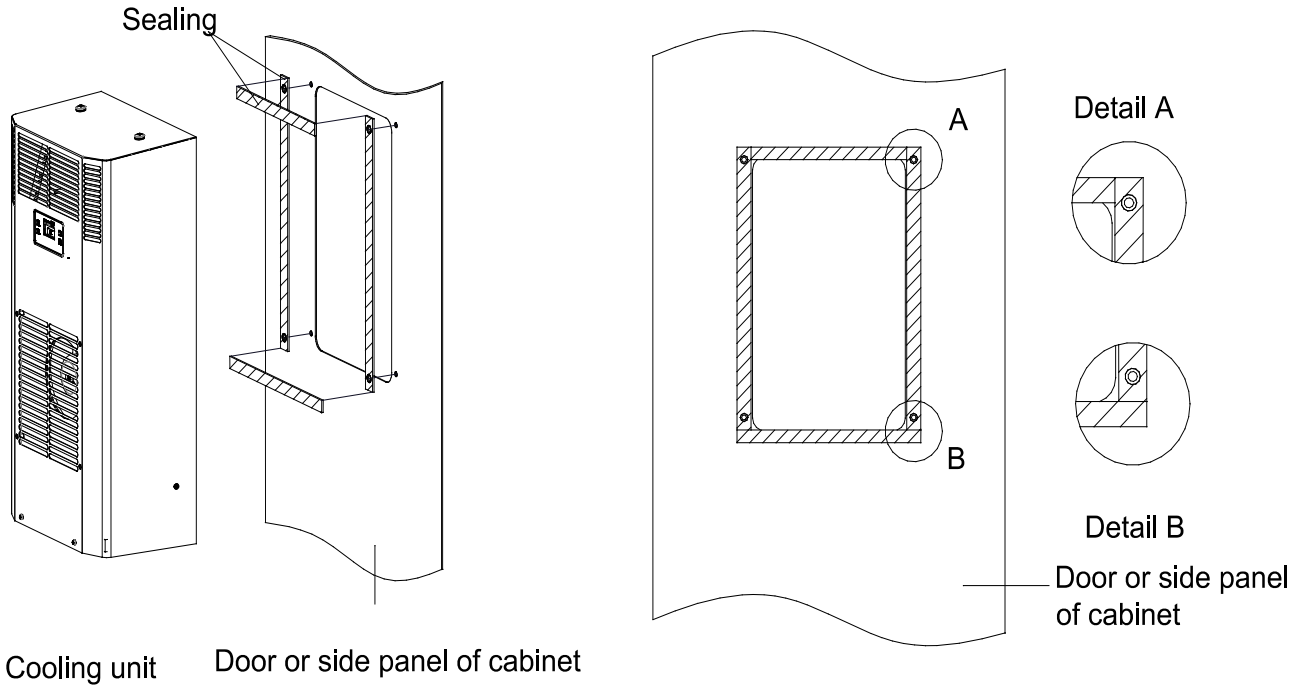

Cut out Dimension

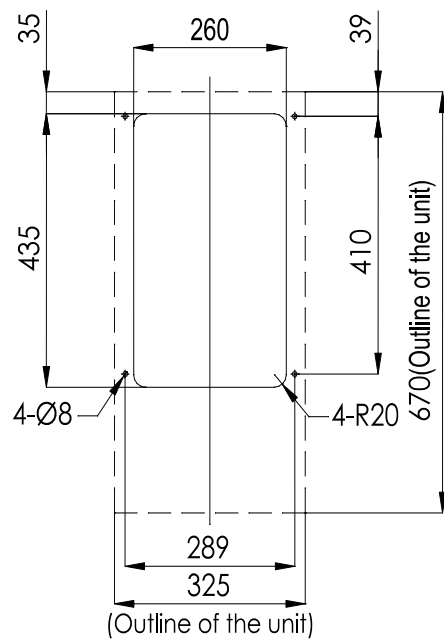

DTS 8241E/8341E/8441E/8541E

Explosive view of the sealing

Effect view of the sealing

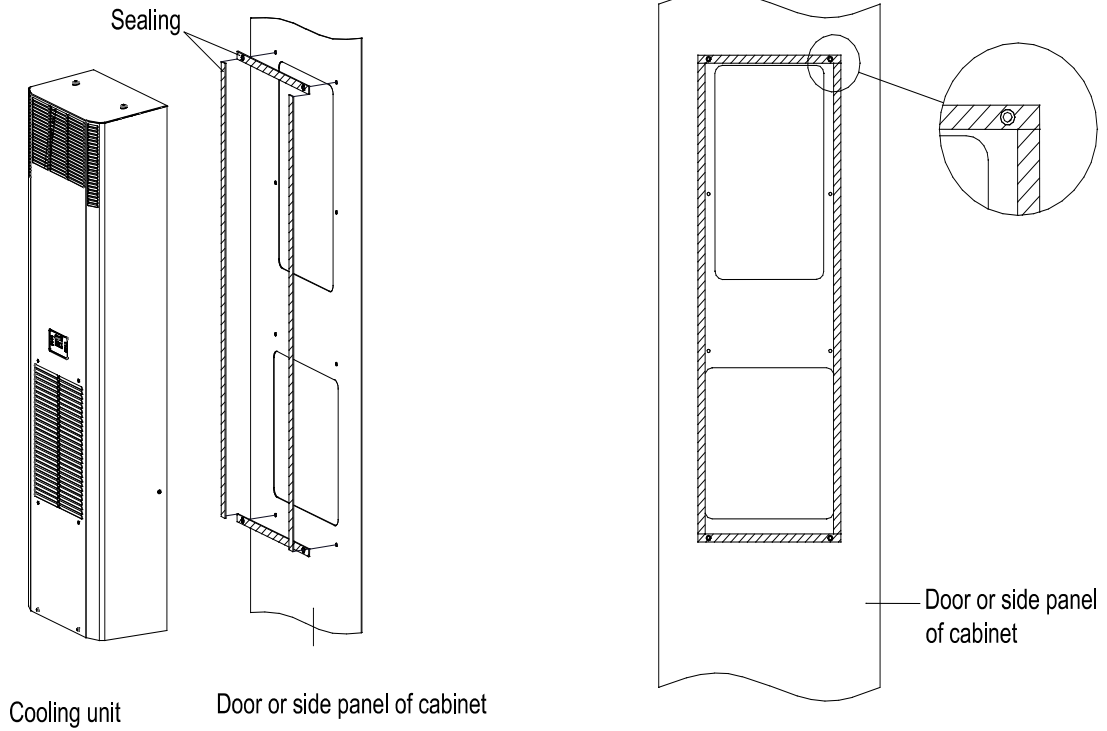

Cut out Dimension

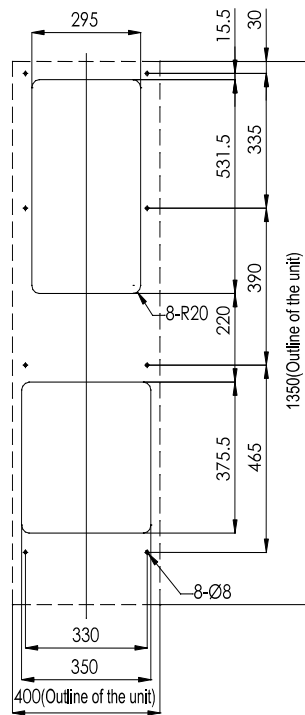

8.4 Airflow principle

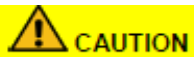
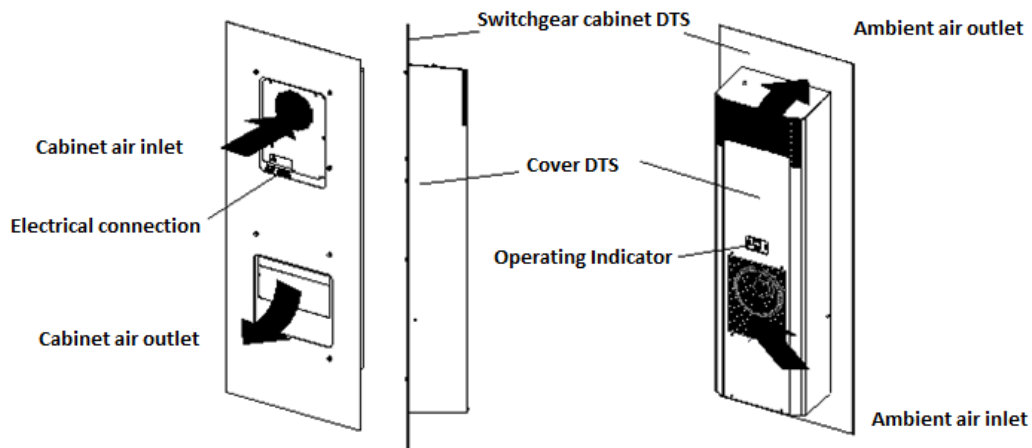

Read this manual completely and carefully before installing the unit.
Prior to mounting, ensure that the clearance of the units to each other and to the wall is at least 200mm; air inlet and outlet are not obstructed on the inside of the enclosure.

8.5 Technical Data

Cooling data		DTS 8021E	
Cooling capacity at A35/A35 * **	Q ₀	300 W	
Cooling capacity at A50/A35 * **	Q ₀	150 W	
Refrigerant type *		R 134a	
Refrigerant amount *		120 g	
Thermostat setting, (factory set)		+35°C (+95°F)	
failure indication: Enclosure internal temp. (factory set)		> +50°C (+122°F)	
Ambient air temperature		+15°C (+59°F) . . . +55°C (+131°F)	
Enclosure internal temp.		+25°C (+77°F) . . . +45°C (+113°F)	
Air volume, external circulation °)		282 m ³ /h	
Air volume, internal circulation °)		224 m ³ /h	
Condensation discharge		Condensate discharge pipe.	
Noise level (1m)		≤ 62 dB(A)	
<i>Electrical data</i>			
Mains frequency		50 Hz	
Operating range		DIN IEC 60038	
Rated voltage		230 V	
Power consumption *(A35/A35) :	P _{el}	285 W	
Current capacity *	I _{nom max}	1,7 A	
Starting current *	I _{Start max}	3,0 A	
<i>Dimensions</i>			
Height X Width X Depth °°)		400 X 282 X 160 (mm)	
Weight		11.5kg	
Installation position		vertical	
Unit construction		Standard: steel Option: Stainless	
Corrosion protection		Standard: galvanized, electrostatically powder coated(200°C) Option: Stainless, Aluminium	
Protection system according to EN 60529		IP54 against the enclosure, under correct operating conditions. IP34 against the environment, under correct operating conditions.	

Cooling data		DTS 8031E	
Cooling capacity at A35/A35 * **	Q ₀	500 W	
Cooling capacity at A50/A35 * **	Q ₀	330 W	
Refrigerant type*		R 134a	
Refrigerant amount*		190 g	
Thermostat setting, (factory set)		+35°C (+95°F)	
Failure indication: Enclosure internal temp. (factory set)		> +50°C (+122°F)	
Ambient air temperature		+15°C (+59°F) . . . +55°C (+131°F)	
Enclosure internal temp		+25°C (+77°F) . . . +45°C (+113°F)	
Air volume, external circulation °)		590 m ³ /h	
Air volume, internal circulation °)		275 m ³ /h	
Condensation discharge		Condensate discharge pipe.(Option: condensate evaporator)	
Noise level (1m)		≤ 63 dB(A)	
Electrical data			
Mains frequency		50 Hz	
Operating range		DIN IEC 60038	
Rated voltage		230 V	400 V
Power consumption *(A35/A35) :	P _{el}	289 W	358 W
Current capacity *	I _{nom max}	1.7 A	1.58 A
Starting current *	I _{Start max}	3.5 A	3.5 A
Condensate evaporator(CM)	P _{el}	Option 30-110W (A35/A35 ca. 70W)	
Dimensions			
Height X Width X Depth °°)		670 X 325 X 200 (mm)	
Weight		17.3 kg	25.3 kg
CM Weight		Option: 0.5kg	
Installation position		vertical	
Unit construction		Standard: steel Option: Stainless	
Corrosion protection		Standard: galvanized, electrostatically powder coated (200°C) Option: Stainless, Aluminium	
Protection system according to EN 60529		IP54 against the enclosure, under correct operating conditions. IP34 against the environment, under correct operating conditions.	

Cooling Data		DTS 8241E	
Cooling capacity at A35/A35 * **	Q ₀	1000 W	
Cooling capacity at A50/A35 * **	Q ₀	840 W	
Refrigerant type *		R 134a	
Refrigerant amount *		430 g	
Thermostat setting, (factory set)		+35°C (+95°F)	
Failure indication: Enclosure internal temp. (factory set)		> +50°C (+122°F)	
Ambient air temperature		+15°C (+59°F) . . . +55°C (+131°F)	
Enclosure internal temp.		+25°C (+77°F) . . . +45°C (+113°F)	
Air volume, external circulation °)		1000 m ³ /h	
Air volume, internal circulation °)		570 m ³ /h	
Condensation discharge		Condensate discharge pipe.(Option: condensate evaporator)	
Noise level (1m)		≤ 65 dB(A)	
Electrical data			
Mains frequency		50 Hz	
Operating range		DIN IEC 60038	
Rated voltage		230 V	400 V
Power consumption *(A35/A35):	P _{el}	513 W	589 W
Current capacity *	I _{nom max}	3.1 A	2.25 A
Starting current *	I _{Start max}	10.5 A	10.5 A
Condensate evaporator(CM)	P _{el}	Option: 30-110W (A35/A35 ca. 70W)	
Dimensions			
Height X Width X Depth °°)		1350 X 400 X 200 (mm)	
Weight		33.5 kg	41.2 kg
CM Weight		Option: 0.5kg	
Installation position		Vertical	
Unit construction		Standard: steel	Option: Stainless
Corrosion protection		Standard: galvanized, electrostatically powder coated (200°C) Option: Stainless, Aluminium	
Protection system according to EN 60529		IP54 against the enclosure, under correct operating conditions. IP34 against the environment, under correct operating conditions.	

Cooling data		DTS 8341E	
Cooling capacity at A35/A35 * **	Q ₀	1500 W	
Cooling capacity at A50/A35 * **	Q ₀	900 W	
Refrigerant type *		R 134a	
Refrigerant amount *		430 g	
Thermostat setting, (factory set)		+35°C (+95°F)	
Failure indication: Enclosure internal temp. (factory set)		> +50°C (+122°F)	
Ambient air temperature		+15°C (+59°F) . . . +55°C (+131°F)	
Enclosure internal temp.		+25°C (+77°F) . . . +45°C (+113°F)	
Air volume, external circulation °)		1000 m³/h	
Air volume, internal circulation °)		1000 m³/h	
Condensation discharge		Condensate discharge pipe (Option: condensate evaporator)	
Noise level (1m)		≤ 65 dB(A)	
Electrical data			
Mains frequency		50 Hz	
Operating range		DIN IEC 60038	
Rated voltage		230 V	400 V
Power consumption *(A35/A35) :	P _{el}	596 W	632 W
Current capacity *	I _{nom max}	3.48 A	2.45 A
Starting current *	I _{Start max}	11 A	11 A
Condensate evaporator(CM) (CM)	P _{el}	Option: 30-110W (A35/A35 ca. 70W)	
Dimensions			
Height X Width X Depth °°)		1350 X 400 X 200 (mm)	
Weight		34.1 kg	41.8 kg
CM Weight		Option: 0.5kg	
Installation position		Vertical	
Unit construction		Standard: steel Option: Stainless	
Corrosion protection		Standard: galvanized, electrostatically powder coated (200°C) Option:Stainless, Aluminium	
Protection system according to EN 60529		IP54 against the enclosure, under correct operating conditions. IP34 against the environment, under correct operating conditions.	

Cooling data		DTS 8441E	
Cooling capacity at A35/A35 * **	Q ₀	2000 W	
Cooling capacity at A50/A35 * **	Q ₀	1400 W	
Refrigerant type *		R 134a	
Refrigerant amount *		850 g	
Thermostat setting, (factory set)		+35°C (+95°F)	
Failure indication: Enclosure internal temp. (factory set)		> +50°C (+122°F)	
Ambient air temperature		+15°C (+59°F) . . . +55°C (+131°F)	
Enclosure internal temp.		+25°C (+77°F) . . . +45°C (+113°F)	
Air volume, external circulation °)		1340 m³/h	
Air volume, internal circulation °)		1000 m³/h	
Condensation discharge		Condensate discharge pipe. (Option: condensate evaporator)	
Noise level (1m)		≤ 66 dB(A)	
Electrical data			
Mains frequency		50 Hz	
Operating range		DIN IEC 60038	
Rated voltage		230 V	400 V
Power consumption *(A35/A35) :	P _{el}	734 W	784 W
Current capacity *	I _{nom max}	5.8 A	5.1 A
Starting current *	I _{Start max}	15 A	15 A
Condensate evaporator(CM)	P _{el}	Option: 30-110W (A35/A35 ca. 70W)	
Dimensions			
Height X Width X Depth °°)		1350 X 400 X 230 (mm)	
Weight		43 kg	50.7 kg
CM Weight		Option: 0.5kg	
Installation position		Vertical	
Unit construction		Standard:steel Option: Stainless	
Corrosion protection		Standard: galvanized, electrostatically powder coated (200°C) Option:Stainless, Aluminium	
Protection system according to EN 60529		IP54 against the enclosure, under correct operating conditions. IP34 against the environment, under correct operating conditions.	

Cooling data		DTS 8541E	
Cooling capacity at A35/A35 * **	Q ₀	2500 W	
Cooling capacity at A50/A35 * **	Q ₀	1800 W	
Refrigerant type *		R 134a	
Refrigerant amount *		760 g	
Thermostat setting, (factory set)		+35°C (+95°F)	
Failure indication: Enclosure internal temp. (factory set)		> +50°C (+122°F)	
Ambient air temperature		+15°C (+59°F) . . . +55°C (+131°F)	
Enclosure internal temp.		+25°C (+77°F) . . . +45°C (+113°F)	
Air volume, external circulation °)		1490 m ³ /h	
Air volume, internal circulation °)		1490 m ³ /h	
Condensation discharge		Condensate discharge pipe (Option: condensate evaporator)	
Noise level (1m)		≤ 67 dB(A)	
Electrical data			
Mains frequency		50 Hz	
Operating range		DIN IEC 60038	
Rated voltage		230 V	400 V
Power consumption *(A35/A35) :	P _{el}	1068 W	1089 W
Current capacity *	I _{nom max}	7.9 A	7.0 A
Starting current *	I _{Start max}	18.4 A	18.4 A
Condensate evaporator(CM)	P _{el}	Option: 30-110W (A35/A35 ca. 70W)	
Dimensions			
Height X Width X Depth °°)		1350 X 400 X 250 (mm)	
Weight		49.3 kg	62.7 kg
CM Weight		Option: 0.5kg	
Installation position		Vertical	
Unit construction		Standard: steel Option: Stainless	
Corrosion protection		Standard: galvanized, electrostatically powder coated (200°C) Option: Stainless, Aluminium	
Protection system according to EN 60529		IP54 against the enclosure, under correct operating conditions. IP34 against the environment, under correct operating conditions.	

*ID Plate Information, ** Cooling capacity without filter mats (option)

°) free-blowing, °°) need additional electrical terminal space 40mm

9 Installations

9.1 General

- For effective cooling & ventilation, correct installation & ventilation of the cooling unit is very important.
- The distance must be kept at least 200mm between units or the unit to the wall.
- The cooling unit's electrical connection terminal requires at least 40mm space and the electrical components shall not impede air circulation in the internal cabinet.
- The power supply must be switched off when installing the cooling unit.
- The site of installation must be protected against contamination.

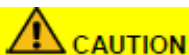

If the cooling unit is mounted on a switch cabinet door, it must be confirmed that hinges can support the additional weight or that the switch cabinet will not topple over when the door is opened.

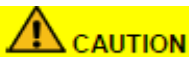

Burrs may damage the switch cabinet. When making a hole on site, a cover sheet must be used to avoid the burrs entering into the cabinet which may damage the electrical components.

NOTE

To facilitate installation with heavy units, M8 eyebolt can be screwed into the upper fixing point on the top of the equipment housing. Simple "one man installation" is thereby possible.

9.2 Installation work

The mounting surface of the switch cabinet is to be provided with cutout(s) and holes for air ventilation openings and for securing the unit according to cut-out dimension.

- 1) If the cabinet is not prepared with mounting cutout, please make cut-out on the cabinet (refer to cut-out dimension), then remove burrs from the cut edge.
- 2) Please stick sealing strips (Pos. 8, 9 or 10, 11, 12) on the outside of the cabinet, make sure holes for screws on the sealing strip 8 or 11 concentric with holes on the switch cabinet, the sealing strip 9 or 10 & 12 and 8 or 11 align at outside line.
- 3) Please put in place of the thread rod, flat gasket, spring washer, nut and bolt (Pos. 3, 4, 5, 6, 7) on the inside of the cabinet and lock the cooling unit tightly.
- 4) Feed the condensate run-off tube through the opening on the bottom of the unit. Lay the tube with a downward fall. Shorten it if necessary.

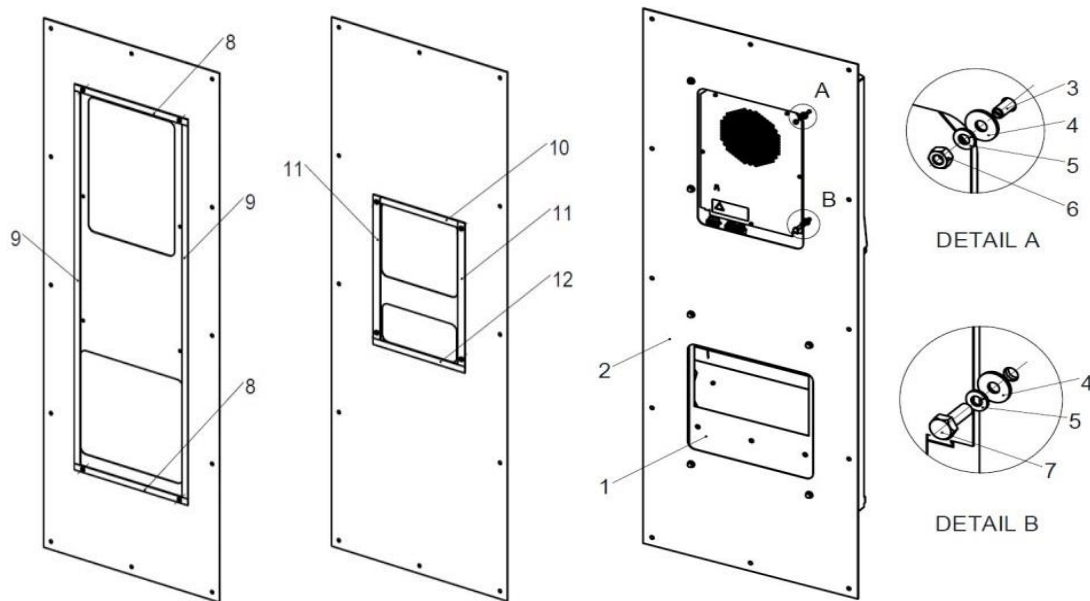

- | | |
|-------------------------------|----------------------------|
| 1 Cooling unit DTS | 5 springs shim |
| 2 switch cabinet wall or door | 6 nuts |
| 3 thread rod | 7 bolts |
| 4 flat gasket | 8,9,10,11,12 sealing strip |

5) If M8 bolts on the top of unit being removed during insatallation, rescew them back to the unit tightly after installation.

6) Clamp the cable as shown in the connection diagram (see backside of unit) to the plug (component pack) [\(see Section 9.3\)](#)

9.3 Electrical connection

CAUTION

- The cooling unit must be connected to the mains by means of a disconnecting device with a contact gap of at least 3mm when switch off.
- No temperature regulator is allowed to be series-connected to the cooling unit up-stream feed.
- The fuse as indicated on the name plate must be series-connected as line protection.
- Power connection and repairs, if applicable, may only be carried out by authorized trained electricians.

Power supply connection:

Both mains voltage and frequency must correspond to the nominal values indicated on the name plate of the cooling unit. There are more labels with signs and explanation on the housing of the unit. Read them carefully before connection.

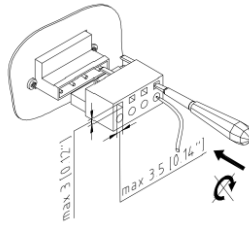

CAUTION

The cooling unit may be damaged if the voltage is too high. It's nominal voltage is 230V or 400V.

10 Operating condition

- The voltage must be within $\pm 10\%$ of the value indicated.
- The frequency must be within $\pm 3\text{Hz}$ of the value indicated.
- Ambient temperature must be below 55°C .
- Use the unit such that the cooling capacity suits the actual demand.
- Use genuine spare parts only.

11 Putting into operation and function

Please refer to [section 7](#) for the function and options.

11.1 General remarks

The cooling unit is provided with an electronic control system. Internal temperature is measured by a temperature sensor. The target setting point of the cooling unit can be set through operating display, ([See Appendix I](#)).

CAUTION

The cooling unit mustn't be switched on without the front cover on, otherwise it will be damaged by poor heat dissipation.

11.2 Operation display

The cooling unit is provided with an operation display. "0.0°C" is displayed for 1s after the power supply is switched on, then cabinet internal temperature is shown. This indicates the unit works properly. If there is a failure or an alarm, the alarm lamp will be turned on and accompanied by an alarm sound, which makes it easier to diagnose the cooling unit. ([Refer to section 15 for diagnosis](#))

11.3 Start-up / Test mode

The cooling unit does not work if the door switch is open. Each time the unit is power-on (when the door switch is closed), the unit performs a start-up process lasting around 3 seconds which is followed by a test mode lasting around 110 seconds. During the test mode, the unit will finish the test process even when an alarm occurs. It enters into a normal working mode if there is no failure. If there is an alarm during start-up, the alarm code will be displayed on the display. The cause must be found & fixed to enable proper functioning.

Mode	Time curve	Characteristics
Start-up mode	t=0s-1s	No function, Operation display shows "0.0°C"
	t=1s-3s	Shows internal temperature
Test mode	t=4s-13s	Internal fan starts up;
	t=14s-23s	External fan starts up
	t=24s-53s	Internal fan stops; Compressor starts up
	t=54s-115s	External fan stops; Internal fan, external fan, compressor all start up together.

11.4 Door contact

For safety reasons, a door limit switch should be connected to the terminals provided on the cooling unit. (see the wiring diagram on housing cover or refer to [circuit diagram](#)). With the switch in place, when enclosure door is open (thereby opening the switch), all of the motors are turned off with a time lag.

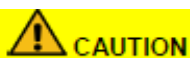

In order to avoid any disruptive influences, it is recommended that a sheathed cable with twisted pair leads be used.

No external voltage is required.

If no door contact switch is used, the connecting contacts are to be bridged.

11.5 Equipment fault

For connection of the fault signal line there are one connection contact and/or connection lines available ([see circuit diagram](#))

Failure contact X54—1,2pin is NC, it closes when power supply is on without alarm, a fault at the cooling unit

will open the failure contact and the alarm code will be shown on the display. ([See Section 15 for trouble shooting](#)).

The installation of the fault signal line is not subject to any special requirement.

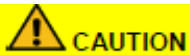

The contact may be loaded with max230V, 1A

12 Parameters View and Settings

Parameters of cooling unit can be monitored and set via operation display.

- Cooling unit control system includes control board, operation display.

Sign	Description	Lighting	Remark
	Self-check	Self-check	Available
	Cooling	Cooling	Available
	Heat	----	Not used
	Humidity	----	Not used
	Fan	Running	Available
	Alarm	Alarm	Available

Operation Display



1. View Parameters

Only internal setting temperature “t1” can be set by user. All other parameters are for diagnosis reference purpose. At home page, press “Select” for 3s, operation display shows “SEE”, press “Select” again, using “▲” or “▼”, user can select following parameters in cycle: “pb1”, “t1”, “dor”, “IFR”, “EFR”, “Con”, “ALr”, at any parameter press “Select” again, corresponding value will be shown, Press “Mode” to go back to previous menu, or wait 5min to go back to home page.

The meaning for each code refer to ([Appendix I](#))

2. Parameter setting

At home page, firstly get into parameters “t1” as described in “View Parameters”. Then press “select” to show the value, then press “▲” for 6S, by pressing “▲” or “▼” to get the desired setting value now. The value changes rapidly by continuous press. Then press “Select” again to confirm the change, Press “Mode” to go back to previous menu, or wait 5min to go back to home page. If no need to change, don't press “Select” for confirmation, just press “Mode” to back to previous menu.

After resetting, the unit must be returned back to home page.

At any parameter interface, press “Mode” to go back to previous menu until home page.

At any interface, home page will be shown without pressing any button for 300s.

13 Cleaning and Maintenance



Please cut off the cooling unit's power before carrying out any cleaning or maintenance operation.

13.1 Cleaning

The operation efficiency and reliability of the equipment will be improved by periodic cleaning and maintenance, call our service team for further service cooperation.

Pay special attention to the following instructions:

•Use a soft brush or compressed air (Medium pressure to avoid damage to the fins).

Proceed as follows:

- 1) Cut off power supply to the cooling unit.
- 2) Remove the external cover.
- 3) Clean the air ventilation channel.
- 4) Clean the external fan.
- 5) Clean the exchangers.
- 6) Put back the external cover
- 7) Connect the power and observe the test mode to make sure the equipment is running properly.

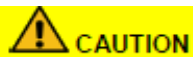

Avoid electrical shock

Prevent damage to the heater exchangers

Don't use any pointed or Sharp-edged objects.

To prevent damage to the electrical connection on the inside of the covering hood, the electrical plug-in connections must be carefully removed before cleaning and reconnected after.

13.2 Maintenance

During equipment malfunction, a fault alarm code will be shown on the display. Please refer to the trouble shooting guide below to identify & rectify the fault.

After every service & maintenance, please complete the power-on self test process to ensure that the cooling unit is functioning properly.

14 When not in used

Please switch off the cooling unit when it is not in use for a longer period of time. Ensure that non-authorized

persons cannot start the cooling unit.

When the cooling unit is no longer needed, it must be disposed of by authorized personnel in accordance with all applicable environmental protection regulations. [\(See section 4\)](#)

15 Trouble shooting

In spite of careful maintenance, the equipment may still have a failure sometime in the future. The real-time self-check function can diagnose the failure.

If a fault occurs, the display will show the relevant alarm code, Below is the trouble shooting guide .

Alarm codes list:

Alarm code	description	Trouble shooting method
AL01	Sensor 1 error	1) Check sensor of Pb1; 2) Check the connection cable; 3) Make sure the connection is correct.
AL02	Cabinet door open	1) Check door switch; 2) Make sure the connection is not loose ; 3) Make sure the connection is correct.
AL03	High temperature	1) If alarm AL02, cooling until stops running; 2) Make sure internal fan and external fan work normally; 3) Make sure compressor work normally; 4) Check condenser if it's dirty or blocked; 5) Check internal fan air channel; 6) Check heat load.

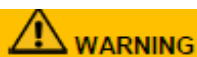

Non-authorized personnel should not repair the equipment.

16 Warranty Conditions

Warranty becomes null and void:

- In case of improper usage of the unit, noncompliance with operating conditions or non observance of instructions;
- If operated in rooms in which corrosives or acids are present in the atmosphere;
- In case of damage caused by contaminated or jammed air filters;
- If a non-authorized person interrupts the cooling circulation, modifies the unit or changes the serial number;
- In case of damage caused by transport or by accidents;
- For the exchange of parts by unauthorized companies;

In order to maintain your warranty rights please observe the following when returning the unit;

- Enclose an exact description of the fault in the shipping package.
- Enclose proof of delivery (delivery note or copy of invoice).
- Return the unit together with all accessories;use the original packaging or packaging of equivalent quality, send the unit freight prepaid and covered by an adequate transport insurance. Observe the hints on transport mentioned [in section 2](#)

Appendix I

Shown parameters (operation display)

Parameter	Description	Min.	Max.	Default	Unit
Pb1	Temperature of internal return air (measurable range)	-30	60	-	°C
t1*	Internal setting temperature (setting range)	25	45	35	°C
Dor	Door switch, 0 means open, 1means close	0	1	-	-
IFR	Internal fan, 0 means OFF, 1 means ON	0	1	-	-
EFR	External fan, 0 means OFF, 1 means ON	0	1	-	-
Con	Compressor, 0 means OFF, 1 means ON	0	1	-	-
ALr	Alarm, 0 means alarm output, 1 means units work normal	0	1	-	-
AL01	Sensor 1 error, 0 means alarm, 1 means normal	0	1	-	-
AL02	Cabinet door open, 0 means alarm, 1 means normal	0	1	-	-
AL03 **	High temperature, 0 means alarm, 1 means normal	0	1	-	-

* Only "t1" can be changed by user. Others are for diagnosis reference.

**The high temperature alarm point is 15 °C higher than "t1". The high temperature alam goes off when internal temperature is 5 °C under alarm point.

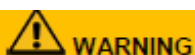

Please don't change any unmentioned parameter other than t1, the equipment will not work properly otherwise.

百能堡电气科技（苏州）有限公司

中国苏州工业园区杏林街 108 号

邮编：215026

电话：+86-512-6287-1078

传真：+86-512-6287-1077

邮箱：service@pfannenbergn.cn

<http://www.Pfannenbergnchina.com>

Pfannenbergn Electro-Technology (Suzhou) Co.,Ltd.

No. 108 Xinglin street, SIP, Suzhou 215026, Jiangsu, P.R.C

Tel: +86-512-6287-1078

Fax: +86-512-6287-1077

e-mail: service@pfannenbergn.cn

Pfannenbergn
ELECTRO-TECHNOLOGY FOR INDUSTRY

